

iDS-TLG20BF3-IR50

High Performance ANPR Bullet Camera

DarkFighter

DeepinView



- 1/1.8" progressive scan CMOS
- 50 Hz: 2688 × 1520 @ 25 fps
- 60 Hz: 2688 × 1520 @ 30 fps
- Color: 0.001 Lux @ (F1.2, AGC ON),
0.0005 Lux with IR
- H.265, H.264
- 140 dB WDR
- 3D DNR
- Alarm I/O
- 1 RS-485 interface
- IR range up to 100 m
- Two defined streams
- Built-in microSD/TF card, up to 128 GB
- License plate recognition
- IP67, IK10



Superiority

- Dedicated camera for ANPR
 - HD resolution
 - Integrated IR
 - Professional shutter speed control
- Built-in ANPR engine, equipped with AI algorithm

Application

- Vehicle control
- Traffic monitoring
- Toll collection
- Security

Scenarios

- Tunnel
- Toll station
- Urban road
- Parking entrance

Smart Function

- Support vehicle model classification
- Support vehicle color identification
- Support no-plate vehicle capture
- Support driving direction detection
- Support motorcycle capture



Specification

Camera	iDS-TLG20BF3-IR50	iDS-TLG20BF3-IR100
Image Sensor	1/1.8" progressive scan CMOS	
Min. Illumination	Color: 0.001 Lux @ (F1.2, AGC ON), 0.0005 Lux with IR	
Shutter Speed	1/25 s to 1/100,000 s	
Slow Shutter	Supported	
Day & Night	IR cut filter	
Digital Noise Reduction	3D DNR	
WDR	140 dB	
Lens		
Focal Length	4-11 mm	8-32 mm
Aperture	F1.38	F1.63-1.8
Focus	Auto	
Auto-iris	DC drive	
FOV	Horizontal FOV: 114.7° to 41.9°; Vertical FOV: 59.4° to 23.6°; Diagonal FOV: 141.5° to 48.1°	Horizontal FOV: 39.7° to 15.9°; Vertical FOV: 22.3° to 9.1°; Diagonal FOV: 45.8° to 18.1°
IR		
IR Range	Up to 50 m	Up to 100 m
Wavelength	850 nm	
Compression Standard		
Video Compression	Main stream: H.265/H.264/MJPEG Sub-stream: H.265/H.264/MJPEG Third Stream: H.265/H.264/MJPEG	
H.264 Type	Baseline profile/Main profile/High profile	
H.265 Type	Baseline profile/Main profile/High profile	
Video Bit Rate	32 Kbps to 16 Mbps	
Audio Compression	G.711/G.722.1	
Audio Bit Rate	8Kbps (G.711) /16Kbps (G.722.1)	
Smart Feature		
Recognition	License Plate Recognition	
Smart Function	Vehicle type classification, color identification, no-plate vehicle capture, vehicle driving direction detection	
Road Traffic and Vehicle Detection		

Countries/Regions	<p>Middle East: The United Arab Emirates (Abu Dhabi, Ajman, Dubai, Fujairah, Ras Al Khaimah, Sharjah and Umm Al Quwain), Qatar, Iran, Iraq, Egypt, Jordan, Kuwait, Saudi Arabia, Pakistan, Oman, Lebanon, Bahrain</p> <p>Africa: Nigeria, Kenya, Ivory Coast, South Africa, Tanzania, Mauritius, Morocco, Tunisia, Sierra Leone, Zambia, Ghana, Zimbabwe, Uganda, Angola, Ethiopia, Senegal, Algeria</p> <p>Asia-Pacific: Australia, New Zealand, Indonesia, Malaysia, Singapore, South Korea, Thailand, Vietnam, the Philippines, Hong Kong, Macao, Taiwan, Burma, India, Mongolia, Cambodia, Laos, Bangladesh</p> <p>America: The United States of America, Canada, Argentina, Chile, Paraguay, Uruguay, El Salvador, Bolivia, Colombia, Brazil, Ecuador, Peru, Mexico, Panama, Costa Rica, Trinidad and Tobago, the Dominican Republic, Guatemala</p> <p>Europe: Turkey, Croatia, Slovakia, Czech Republic, Bulgaria, the Republic of North Macedonia, Hungary, Greece, Poland, France, Netherlands, Switzerland, Spain, the UK, Ireland, Germany, Italy, Austria, Israel, Palestinian State, Belgium, Luxembourg, Albania, Bosnia and Herzegovina, The Republic of Serbia, Montenegro, The Republic of North Macedonia</p> <p>Russian-Speaking Regions: Azerbaijan, Belarus, Kazakhstan, Lithuania, Georgia, Estonia, Latvia, Russia, Ukraine, Moldova, Uzbekistan, Kyrgyzstan, Armenia</p>
Accuracy (Under recommended installation and lighting conditions)	<p>Capture rate > 99%</p> <p>Driving direction recognition accuracy > 98.5%</p> <p>LPR accuracy > 98%</p> <p>Mistaken capture rate < 2%</p> <p>European and Russian-Speaking Regions: LPR accuracy > 98%</p> <p>Country/Region recognition accuracy > 95%</p>
No License Plate Detection	Supported
Target Detection	Motor vehicle, non-motor vehicle, pedestrian
Motorcycle LPR	Supported
Vehicle Type	Car/Van/Bus/Truck/Light Truck/SUV_MPV/Pickup/Motorcycle/Tricycle
Vehicle Color	Red, yellow, green, blue, pink, purple, cyan, brown, white, grey, black IR Model: Recognizable at daytime only
Vehicle Manufacturer	84 manufacturers: Hyundai, Toyota, KIA, Honda, Volkswagen, Benz, Nissan, Ford, Isuzu, BMW, Chevrolet, Mitsubishi, Renault, Opel, Suzuki, Skoda, Daewoo, Audi, Mazda, GAC HINO, Peugeot, SsangYong, Citroen, Fiat, Scania, MAN, Volvo, Lexus, Seat, Land Rover, Daihatsu, Dongwo, Subaru, Iveco, MINI, JEEP, Porsche, Chery, Dodge, Chrysler, Acura, Alfa Romeo, Great Wall, Infiniti, Smart, Saic Maxus, JAC, Jaguar, GMC, Lincoln, JMC, SAAB, FAW, Yutong, Guangzhou Yunbao, Joylong, Geely, Cadillac, JBC, An'kai, Haima, Foton, King Long, Dongfeng, Geely-Emgrand, Perodua, UD, BYD, Renault Samsung, Proton, HICOM, Malaysia_Unknown 1, Hyundai-Rohens, SsangYong-Old Version, Equus-Old Version, CNHTC, Rolls-Royce, Beiben Truck, Haval, Hino, Kia-Borrego, Chang'an, Alfa, FORO
Capture Speed Range	5 to 120km/h
Image	
Max. Resolution	2688 × 1520
Main Stream	50 Hz: 25 fps (2688 × 1520, 1920 × 1080, 1280 × 720, 704 × 576, 352 × 288) 60 Hz: 30 fps (2688 × 1520, 1920 × 1080, 1280 × 720, 704 × 576, 352 × 288)
Sub-Stream	50 Hz: 25 fps (1920 × 1080, 1280 × 720, 704 × 576, 352 × 288) 60 Hz: 30 fps (1920 × 1080, 1280 × 720, 704 × 576, 352 × 288)

Third Stream	50 Hz: 25 fps (1280 × 720, 704 × 576, 352 × 288) 60 Hz: 30 fps (1280 × 720, 704 × 480, 640 × 480)
Image Enhancement	BLC, HLC, 3D DNR
Image Settings	Rotation mode, saturation, brightness, contrast, sharpness, AGC, and white balance are adjustable via client software or web browser.
SVC	H.264 and H.265 encoding
Day/Night Switch	Auto/Scheduled/Triggered by alarm in
Picture Overlay	Logo picture can be overlaid on video with 128 × 128 in 24bit bmp format
Network	
Network Storage	microSD/TF card (128 GB), local storage and CVR, NVR, ANR
Alarm Trigger	HDD Error, Network Disconnected, IP Address Conflicted, Vehicle Detector Exception, Traffic Light Detector Exception
Protocols	TCP/IP, HTTP, HTTPS, FTP, DNS, RTP, RTSP, RTCP, NTP, IPv6, UDP
Security Measures	Password protection, HTTPS encryption, digest authentication for HTTP/HTTPS, digest authentication for ONVIF (Version 2.1)
General Function	One-key reset, three streams, heartbeat, password protection, watermark
API	ONVIF (Version 2.1, PROFILE S, PROFILE G), ISAPI, SDK
Simultaneous Live View	Up to 6 channels
User/Host	Up to 32 users 3 user levels: administrator, operator, and user
Client	iVMS-4200 (Only for video live view and LPR information search), HikCentral Master, HikCentral Master Lite, HikCentral Pro
Web Browser	IE8-IE11, plug-in free live view supported
Interface	
Audio	Supported
Communication Interface	1 RJ45 10M/100M/1000M Ethernet interface 1 RS-485 interface 1 Wiegand interface
Alarm	1 input interface, 1 output interface, 2 relays
Video Output	Network
On-Board Storage	Built-in microSD/TF card, up to 128 GB
Reset Button	Supported
General	
Operating System	Linux
Certifications	CE, FCC, CB, UL, IP67, IK10
Operating Conditions	Temperature: -30 °C to +70 °C (-22 °F to +158 °F) , Humidity: 95% or less (non-condensing)
Power Supply	12 VDC to 24 VDC ± 20%, PoE (802.3at, class 4)
Protection Level	IP67, IK10
Material	Aluminum alloy
Dimensions	428.5 × 120 × 132.8 mm
Weight	Camera: approx. 3.12 ± 0.5 kg (6.88 ± 1.1 lb)
Power Consumption	Max. 12 W

* Listed resolutions are only selectable options. It does not mean that all streams can work at their maximum resolution at the same time.

Available Model

iDS-TLG20BF3-IR100

iDS-TLG20BF3-IR50

Application Scenario



Urban Road



Mixed Road



Entrance & Exit



Highway Toll Station

Application Performance

- Urban road, mixed road, etc.

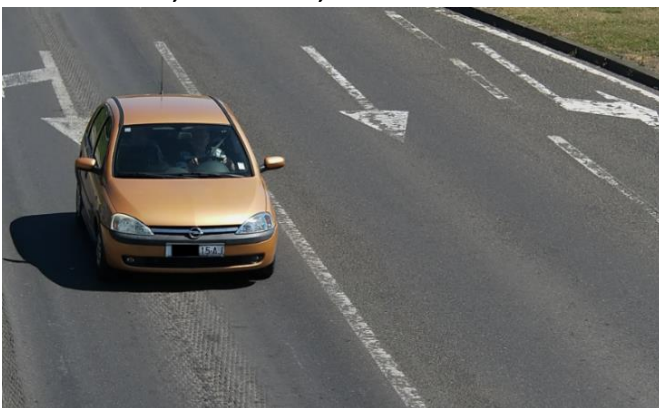

Day



Night



Day



Night

• Entrance & exit, highway toll station, etc.



Day



Night

Dimension

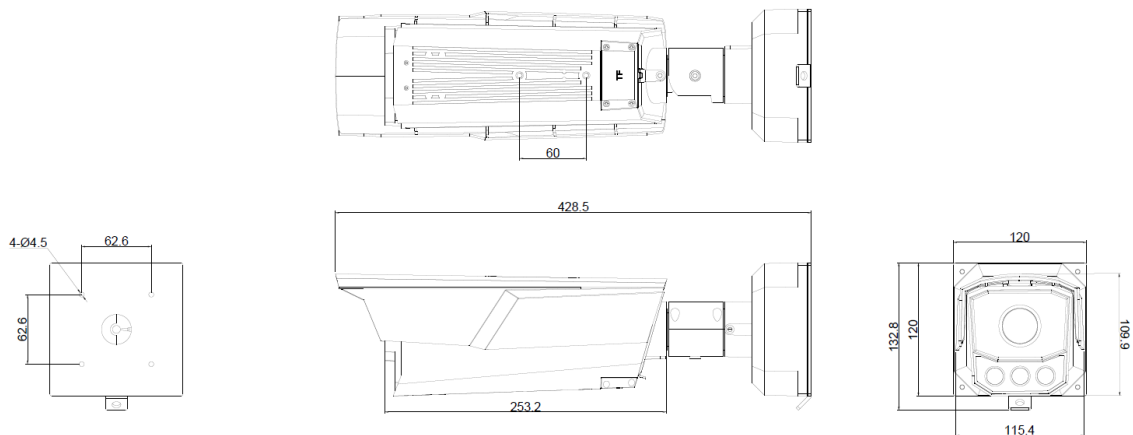

Unit: mm

Accessory

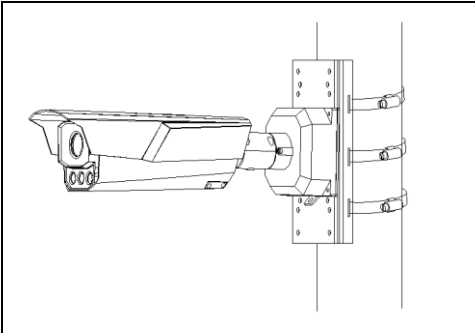

Hoop Bracket
DS-1275ZJ/HWB

Distributed by



HIKVISION®

Headquarters

No.555 Qianmo Road, Binjiang District,
Hangzhou 310051, China
T +86-571-8807-5998
overseasbusiness@hikvision.com

Hikvision USA
T +1-909-895-0400
sales.usa@hikvision.com

Hikvision Australia
T +61-2-8599-4233
salesau@hikvision.com

Hikvision India
T +91-22-28469900
sales@pramahikvision.com

Hikvision Canada
T +1-866-200-6690
sales.canada@hikvision.com

Hikvision Thailand
T +662-275-9949
sales.thailand@hikvision.com

Hikvision Europe
T +31-23-5542770
sales.eu@hikvision.com

Hikvision Italy
T +39-0438-6902
info.it@hikvision.com

Hikvision Brazil
T +55 11 3318-0050
Latam.support@hikvision.com

Hikvision Turkey
T +90 (216)521 7070- 7074
sales.tr@hikvision.com

Hikvision Malaysia
T +601-7652-2413
sales.my@hikvision.com

Hikvision UK & Ireland
T +01628-902140
sales.uk@hikvision.com

Hikvision South Africa
Tel: +27 (10) 0351172
sale.africa@hikvision.com

Hikvision France
T +33(0)1-85-330-450
info.fr@hikvision.com

Hikvision Kazakhstan
T +7-727-9730667
nikia.panfilov@hikvision.ru

Hikvision Vietnam
T +84-974270888
sales.vt@hikvision.com

Hikvision UAE
T +971-4-4432090
salesme@hikvision.com

Hikvision Singapore
T +65-6684-4718
sg@hikvision.com

Hikvision Spain
T +34-91-737-16-55
info.es@hikvision.com

Hikvision Tashkent
T +99-87-1238-9438
uzb@hikvision.ru

Hikvision Hong Kong
T +852-2151-1761
info.hk@hikvision.com

Hikvision Russia
T +7-495-669-67-99
saleru@hikvision.com

Hikvision Korea
T +82-(0)31-731-8817
sales.korea@hikvision.com

Hikvision Poland
T +48-22-460-01-50
info.pl@hikvision.com

Hikvision Indonesia
T +62-21-2933759
Sales.Indonesia@hikvision.com

Hikvision Colombia
sales.colombia@hikvision.com